



User Guide

# ACR7000 Servo Controller



Effective: June 2020

Document Number: 88-033561-11A

## User Information



**Warning:** ACR7000 products are used to control electrical and mechanical components of motion control systems. You should test your motion system for safety under all potential conditions. Failure to do so can result in damage to equipment and/or serious injury to personnel.

ACR7000 products and the information in this guide are the proprietary property of Parker Hannifin Corporation or its licensors, and may not be copied, disclosed, or used for any purpose not expressly authorized by the owner thereof.

Since Parker Hannifin constantly strives to improve all its products, we reserve the right to change this guide, and software and hardware mentioned therein, at any time without notice.

In no event will the provider of the equipment be liable for any incidental, consequential, or special damages of any kind or nature whatsoever, including but not limited to lost profits arising from or in any way connected with the use of the equipment or this guide.

© 2020 Parker Hannifin Corporation  
All Rights Reserved

### Contact Information for Technical Assistance

Contact your local automation technology center (ATC) or distributor.

#### North America and Asia

Parker Hannifin  
Electromechanical & Drives Division North America  
5500 Business Park Drive  
Rohnert Park, CA 94928  
Telephone: (707) 584-7558  
Fax: (707) 584-8029  
Email: [emn\\_support@parker.com](mailto:emn_support@parker.com)  
Internet: <http://www.parkermotion.com>

#### Europe

Parker Hannifin  
Electromechanical Automation Europe  
Robert-Bosch-Strasse 22  
77656 Offenburg (Germany)  
Telephone: +49 (0781) 509-0  
Fax: +49 (0781) 509-98176  
Email: [em-motion@parker.com](mailto:em-motion@parker.com)  
Internet: [www.parker.com/eme](http://www.parker.com/eme)



Product Type: ACR7000 Servo Drive Controllers, including model ACR74V-A5V4CI and ACR78V-A5V4CI

The above product complies with the requirements of directives:

- 2014/30/EU Electromagnetic Compatibility Directive
- 2011/65/EU Restriction of Hazardous Substances Directive
- CE Marking Directive 93/68/EEC

This product has been shown to meet the CE requirements for Marking (93/68/EEC), Electrical Safety (EN 61800-5-1:2007 (2nd Edition) + A1:2017) and Electromagnetic Compatibility (IEC 61800-3 ed2.0 per 204/108/EC) when installed, operated and maintained as described in the product User Guide.

Per IEC 61800-3 ed2.1 section 3.2.5, the ACR7000 Servo is considered a PDS (Power Drive System) of rated voltage less than 1000V, intended for use in the second environment (industrial) and not intended for direct use in the first environment (residential). This means only those individuals familiar with the EMC requirements of power drive systems should install this product and that this product is designed for connection to mains distribution networks other than low-voltage networks, which may supply domestic premises. The drives can tolerate atmospheric pollution degree 2, which means only dry, non-conductive pollution is acceptable.

### Electrical Safety

EN 61800-5-1:2007 (2<sup>nd</sup> Edition) + A1:2017

Safety requirements for adjustable speed electrical power drive systems

Part 5.1: Safety Requirements – Electrical, Thermal and Energy

### Electromagnetic Compatibility

IEC 61800-3 ed2.1

Adjustable speed electrical power drive systems –

Part 3: EMC requirements and specific test methods

## IMPORTANT USER INFORMATION

---



**Warning:** Risk of damage and/or personal injury.  
The ACR7000 Servo described in this guide contains no user-serviceable parts. Attempting to open the case of any unit, or to replace any internal component, may result in damage to the unit and/or personal injury. This may also void the warranty.

---

The following symbols appear in this guide:

Symbols	Description
	Protective Earth Ground
	Functional Earth (Ground) Terminal
	Shield, Frame, or Chassis Terminal
	Digital Ground
	Isolated Ground
	Caution Risk of Electrical Shock
	Caution, Refer to Accompanying Documentation

## Important Safety Information

It is important that motion control equipment is installed and operated in such a way that all applicable safety requirements are met. It is your responsibility as an installer to ensure that you identify the relevant safety standards and comply with them; failure to do so may result in damage to equipment and personal injury. In particular, you should study the contents of this user guide carefully before installing or operating the equipment.

The installation, set up, test and maintenance procedures given in this user guide should only be carried out by competent personnel trained in the installation of electronic equipment. Such personnel should be aware of the potential electrical and mechanical hazards associated with mains-powered motion control equipment—please see the safety warnings below. The individual or group having overall responsibility for this equipment must ensure that operators are adequately trained.

Under no circumstances will the suppliers of the equipment be liable for any incidental, consequential or special damages of any kind whatsoever, including but not limited to lost profits arising from or in any way connected with the use of the equipment or this guide.

---

**Warning:** High-performance motion control equipment can produce rapid movement and very high forces. Unexpected motion may occur especially during the development of controller programs. **KEEP WELL CLEAR** of any machinery driven by stepper or servo motors. Never touch any part of the equipment while it is in operation.

This product is sold as a motion control component to be installed in a complete system using good engineering practice. Care must be taken to ensure that the product is installed and used in a safe manner according to local safety laws and regulations. In particular, the product must be positioned such that no part is accessible while power may be applied.



This and other information from Parker Hannifin Corporation, its subsidiaries, and authorized distributors provides product or system options for further investigation by users having technical expertise. Before you select or use any product or system, it is important that you analyze all aspects of your application and review the information concerning the product in the current product catalog. The user, through its own analysis and testing, is solely responsible for making the final selection of the system and components and assuring that all performance, safety, and warning requirements of the application are met.

If the equipment is used in any manner that does not conform to the instructions given in this user guide, then the protection provided by the equipment may be impaired.

---

The information in this user guide, including any apparatus, methods, techniques, and concepts described herein, are the proprietary property of Parker Hannifin or its licensors, and may not be copied, disclosed, or used for any purpose not expressly authorized by the owner thereof.

Since Parker Hannifin constantly strives to improve all its products, we reserve the right to modify equipment and user guides without prior notice. No part of this user guide may be reproduced in any form without the prior consent of Parker Hannifin.

## Contents

<b>User Information</b> .....	<b>2</b>
Contact Information for Technical Assistance.....	2
Symbols.....	4
Description.....	4
<b>Important Safety Information</b> .....	<b>5</b>
<b>Contents</b> .....	<b>6</b>
<b>CHAPTER 1 Introduction</b> .....	<b>10</b>
<b>ACR7000 Servo Controllers—Overview</b> .....	<b>11</b>
Product Description.....	11
ACR7000 Part Numbers.....	11
<b>Checking Your Shipment</b> .....	<b>12</b>
<b>Assumptions of Technical Experience</b> .....	<b>12</b>
<b>Technical Support</b> .....	<b>12</b>
<b>CHAPTER 2 Mechanical Installation</b> .....	<b>13</b>
<b>Environment &amp; Drive Cooling</b> .....	<b>14</b>
<b>Dimensions</b> .....	<b>15</b>
Mounting Orientation.....	16
<b>Weight</b> .....	<b>17</b>
<b>Mounting Guidelines</b> .....	<b>17</b>
Cable Routing.....	17
<b>CHAPTER 3 Electrical Installation</b> .....	<b>18</b>
<b>Installation Safety Requirements</b> .....	<b>19</b>
Precautions.....	19
<b>System Installation Overview</b> .....	<b>20</b>

<b>Connectors</b> .....	<b>21</b>
<b>CTRL - Control Power Connector</b> .....	<b>22</b>
Control Power LED.....	23
<b>ENABLE – Enable Input Connector</b> .....	<b>24</b>
<b>MTR PWR - Motor Input Power Connectors</b> .....	<b>25</b>
<b>ENC - Encoder Connectors</b> .....	<b>26</b>
Encoder Connector (0-7) Pinout.....	27
Internal Encoder (0-7) Connections .....	28
Encoder Inputs (0-7) .....	28
Motor Thermal Switch Input .....	29
Encoder Connector (ENC8) Pinout .....	29
Internal Encoder 8 Connections .....	30
<b>I/O Connectors</b> .....	<b>31</b>
I/O Cable .....	32
I/O Connector Pinout .....	33
Digital Inputs .....	34
Outputs—General Purpose .....	35
Outputs—High Speed .....	35
Analog Inputs .....	36
<b>Motor Output Power Connectors</b> .....	<b>37</b>
Motor Output Power .....	37
Motor Output Power Connections .....	38
<b>Brake Relay/Brake Power (Optional)</b> .....	<b>39</b>
Brake Relay (on Output Power Connector) .....	39
Brake Relay Operation.....	39
Brake Relay Specifications .....	39

# TABLE OF CONTENTS

---

Brake Relay Connection .....	40
<b>Regeneration Protection .....</b>	<b>40</b>
<b>CHAPTER 4 Communications .....</b>	<b>42</b>
<b>Overview .....</b>	<b>43</b>
<b>Ethernet Specifications.....</b>	<b>43</b>
Ethernet Cable Specification .....	43
Ethernet Connector.....	43
Ethernet Connector Pinout .....	44
RJ-45 LED Ethernet Status Indicators.....	44
<b>Connecting to a PC.....</b>	<b>45</b>
Setting the IP Address and Subnet Mask—PC.....	45
<b>Verifying the IP Address.....</b>	<b>48</b>
<b>CHAPTER 5 Basic Operation .....</b>	<b>50</b>
<b>Basic Operation.....</b>	<b>51</b>
Parker Motion Manager .....	51
Configuration Wizard.....	51
Memory.....	55
Changing Motor/Drive Parameters.....	56
Motor Feedback.....	56
Commutation and Hall Checking .....	56
<b>Appendix A Accessories .....</b>	<b>58</b>
<b>VM26 Breakout Module.....</b>	<b>59</b>
<b>Cables.....</b>	<b>60</b>





**CHAPTER I**  
**Introduction**



# ACR7000 Servo Controllers—Overview

The ACR7000 Servo, part of the ACR7000 family, is a multi-axis servo drive/controller. Setup and programming are accomplished using the AcroBASIC language within the Parker Motion Manager programming environment.

## Product Description

The ACR7000 Servo shares the control capability and ACROBasic programming language with the ACR7000 family of controllers and integrated drive products. The ACR7000 Servo includes high performance digital servo drives designed to control torque, speed and position of 3-phase servo motors.

## ACR7000 Part Numbers

The following diagram explains the ACR7000 part numbers:

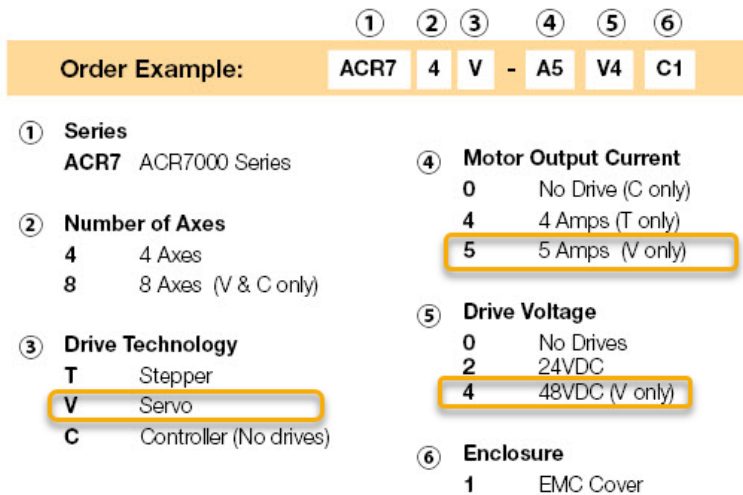

Two unique servo models are available. Except for the number of axes and physical dimensions almost all specifications are shared between the 2 models. This manual will use the designation ACR7xV or ACR7000 Servo when referring to common specifications.

Model	Description
ACR74V-A5V4C1	4 Axis Servo Drive/Controller
ACR78V-A5V4C1	8 Axis Servo Drive/Controller

# Checking Your Shipment

Confirm that you have received all items in the table below. These items ship with the following drives: ACR7000 Servo. If you are missing an item, call the factory. For contact information, see Contact Information for Technical Assistance at the beginning of this guide.

The following items ship with the ACR7000 Servo. The connectors are inserted in the controller during shipment and not packaged separately.

Part Name	Parts per controller	
	ACR74V	ACR78V
Motor Output Connectors, 6 pin (Motor)	4	8
Connector, 4 pin (Power)	2	4
Connector 2 pin (Enable and Control power)	2	2

# Assumptions of Technical Experience

To effectively install and troubleshoot the ACR7000, you must have a fundamental understanding of the following:

- Motion control applications
- Electromechanical actuators
- Voltage, current, switches, and other electrical concepts
- Basic Programming

# Technical Support

For solutions to questions about implementing the drive, first refer to this manual. If you cannot find the answer in this documentation, contact your local Automation Technology Center (ATC) or distributor for assistance.

If you need to talk to our in-house Application Engineers, please contact us at the telephone numbers listed in the “Contact Information for Technical Assistance” table on page 2.

## **CHAPTER 2**

# **Mechanical Installation**



# Environment & Drive Cooling

The ACR7000 Servos operate in an ambient temperature range of 0°C (32°F) to 50°C (120°F) ambient air temperature. The product can tolerate atmospheric pollution degree 2. Only dry, non-conductive pollution is acceptable. Therefore, it is recommended that the product be mounted in a suitable enclosure.

For proper cooling, the ACR7000 must be installed so that the cooling vents allow for vertical air flow. Figure 3 on page 17 shows the mounting orientation, as well as the minimum top, bottom, and side installation clearances.

---

### NOTES:

- **Avoid installing heat-producing equipment directly below a drive.**
- **Make sure the ambient air temperature entering the drive or rising to the drive is within acceptable ambient temperature limits. Under normal use, the temperature of air leaving the drive and heat sink may be 25°C (45°F) above ambient temperature.**
- **After installation, verify that the ambient air temperature directly below the top-most drive does not exceed the maximum Ambient Air Operating Temperature shown below. In addition, make sure that nothing obstructs the circulating airflow.**

---

### Environmental Specifications

<b>Operating Temperature</b>	Maximum 50°C (120°F)
<b>Ambient Air</b>	Minimum 0°C (32°F)
<b>Storage Temperature</b>	-40°C to 85°C (-40°F to 185°F)
<b>Humidity</b>	0 to 95%, non-condensing
<b>Shock</b>	15g, 11 ms half-sine
<b>Vibration</b>	10 to 2000 Hz at 2g
<b>Pollution Degree</b>	2 (per IEC 61010)
<b>Installation Category</b>	2 (per IEC 61010)

# Dimensions

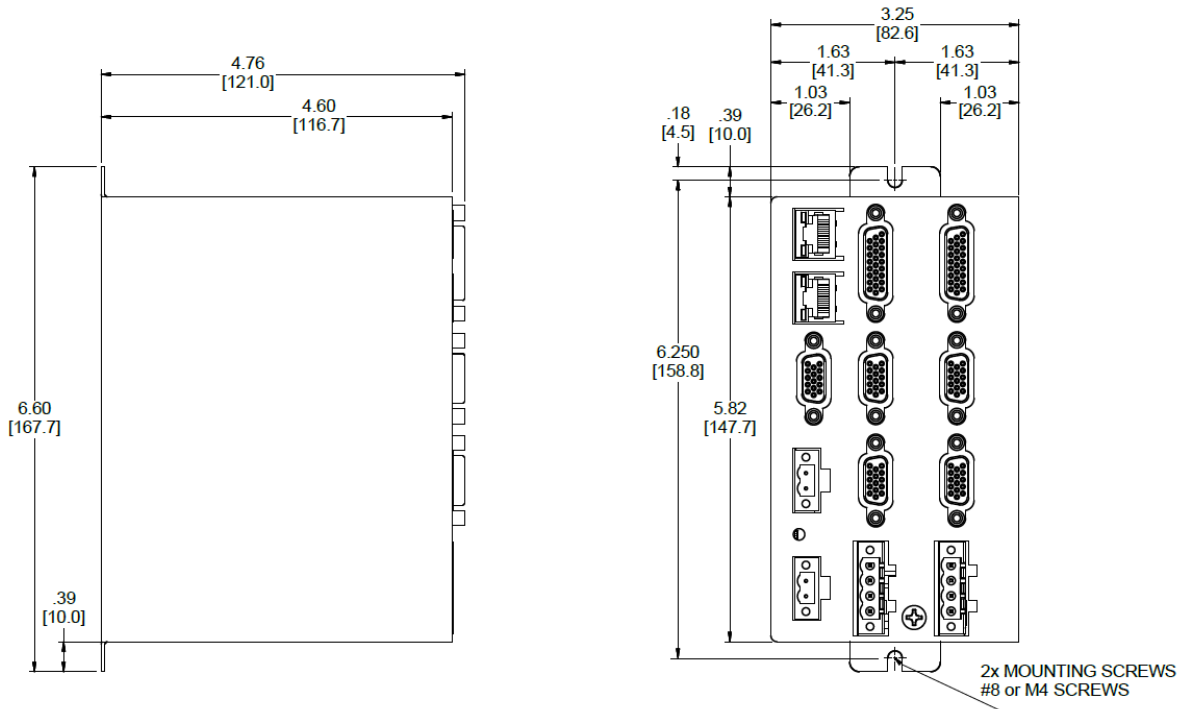

Figure 1. - ACR74V Dimensions

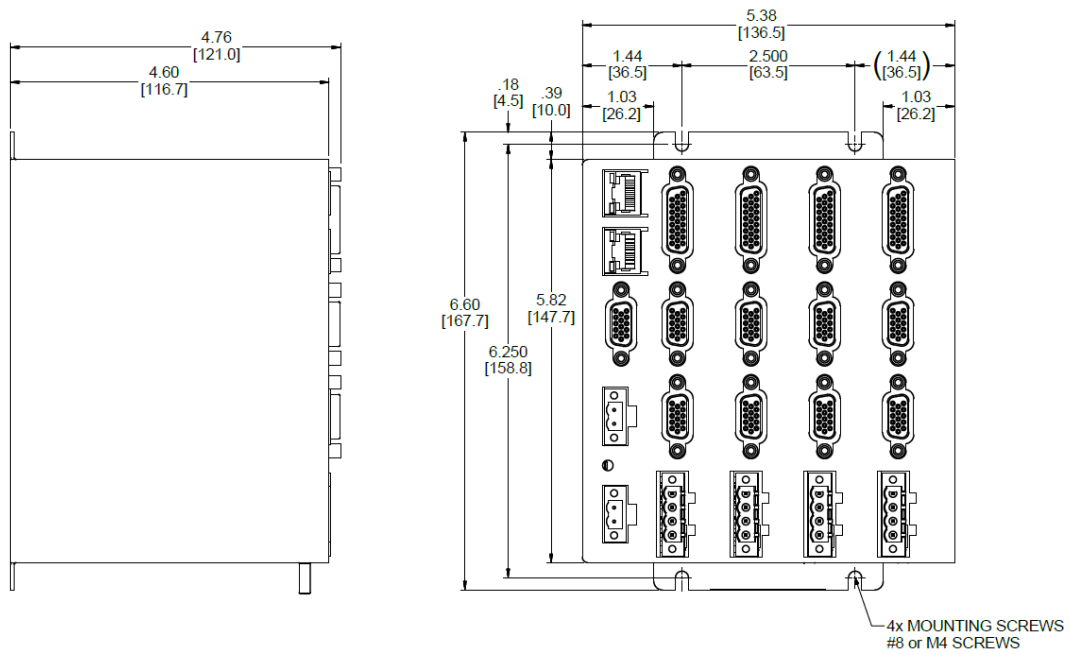

Figure 2. - ACR78V Dimensions

## MECHANICAL INSTALLATION

### Mounting Orientation

The ACR7000 should be mounted to a vertical surface in the orientation shown below to allow for vertical air flow through the cooling vents on the top and bottom of the product. Bottom clearance dimension is the minimum required for proper ventilation. Additional space is recommended to accommodate motor cables.

Consult factory to review applications where vertical mounting is not possible. Product derating may apply.

Note	Inch (mm)
A - Top	1.0 (25)
B - Bottom	2.0 (50)
C - Sides	0.25 (6)

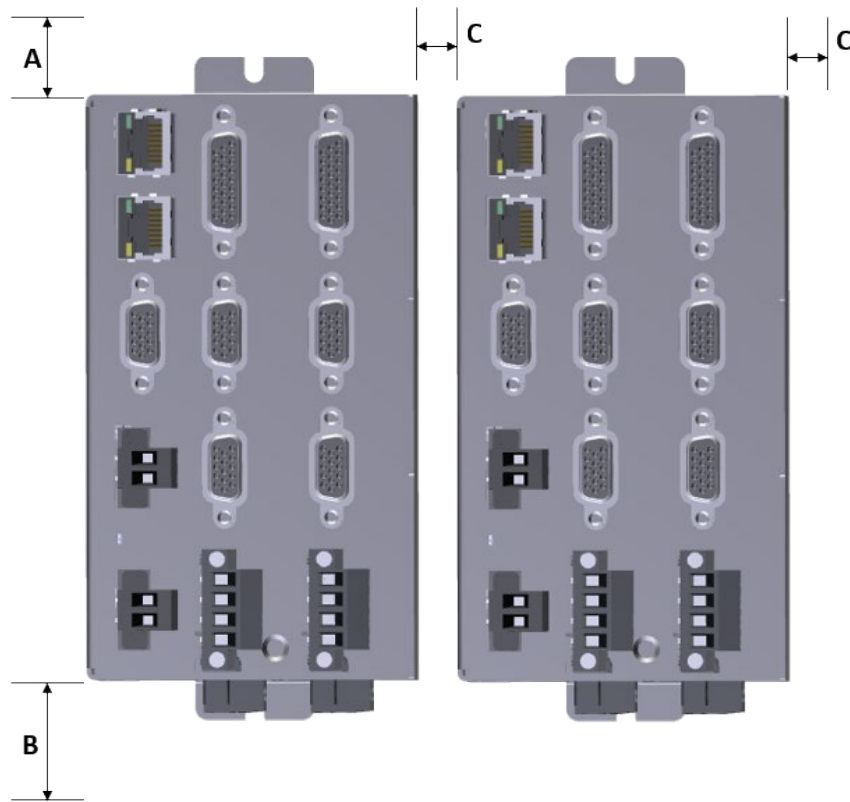

Figure 3. - *Mounting Clearance*



## Weight

The following table lists the weight of each drive/controller model.

### *Drive/Controller Weights*

Model	Weight pounds (kg)
ACR74V	2.8 (1.27)
ACR78V	4.1 (1.86)

## Mounting Guidelines

The ACR7000V Servos are vented products. To prevent material spilling into the drive, mount it under an overhang or in a suitable enclosure and mounted to a metallic, grounded (RF fashion) mounting plate is required to meet the EMC performance required by IEC 61800-3.

ACR7000V products are made available under “Restricted Distribution” for use in the “Second Environment” as described in the publication EN 61800-3 ed2.0.

## Cable Routing

Route high power cables (motor and mains) at right angles to low power cables (communications and inputs/outputs). Never route high and low power cables parallel to each other.

**CHAPTER 3**  
**Electrical Installation**



## Installation Safety Requirements

The ACR7000 Servo has been shown to meet the CE requirements for Marking (93/68/EEC), Electrical Safety (EN 61800-5-1:2007 (2nd Edition) + A1:2017) and Electromagnetic Compatibility (IEC 61800-3 ed2.0 per 204/108/EC) when installed, operated and maintained as described in the product User Guide.

As a rule, it is recommended that you install the ACR7xV in an enclosure to protect it from atmospheric contaminants and to prevent operator access while power is applied. Metal equipment cabinets are ideally suited for housing the equipment because they provide operator protection and EMC screening, and can be fitted with interlocks arranged to remove all hazardous motor and drive power when the cabinet door is opened.

Do not arrange the interlocks to open circuit the motor phase connections while the system is still powered as this could damage the drive/controller.

## Precautions

During installation, take the normal precautions against damage caused by electrostatic discharges.

- Wear earth wrist straps.
- Include a mains power switch or circuit breaker within easy reach of the machine operator. Clearly label the switch or breaker as the disconnecting device.



**Warning:** High-performance motion control equipment can produce rapid movement and very high forces. Unexpected motion may occur especially during the development of controller programs. **KEEP WELL CLEAR** of any machinery driven by stepper or servo motors. Never touch any part of the equipment while it is in operation.

# System Installation Overview

This section details the components and configuration necessary for electrical installation of the ACR7000 Servo.

Installation of a motion control system requires an ACR7000, one or more compatible motors (listed on page 12), VDC Power Supplies and access to a computer. Refer to the following figure for a diagram of this system. Only one motor shown for clarity.

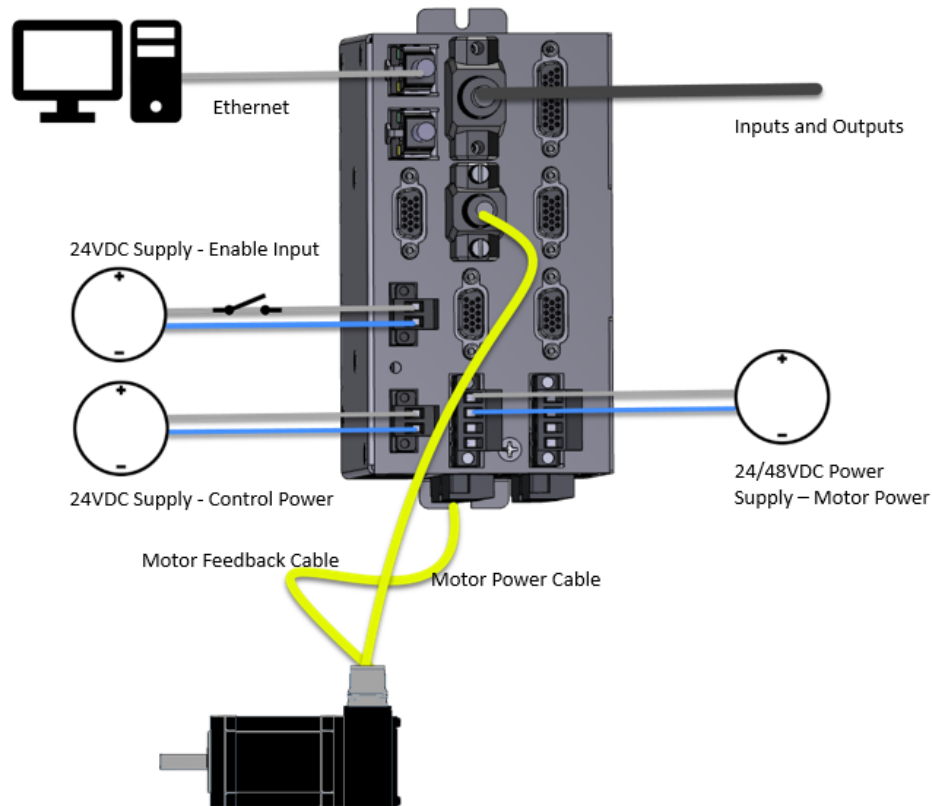

Figure 4. - System Installation Overview

### Startup Process

1. Before powering the system for the first time, disconnect power from the Enable Input.
2. Complete wiring connections outlined in Chapter 3
3. Establish communications via Ethernet. Chapter 4
4. Generate a motor and controller configuration. Chapter 5.
5. Engage enable input and test motion. If undesired motion occurs, disengage Enable Input to stop motion immediately



**Warning:** Before inserting or removing any connectors or wires from the controller, all Input power should be turned off.

# Connectors

Connector specifications are in this section.

The following figure shows the name and location of the connectors.

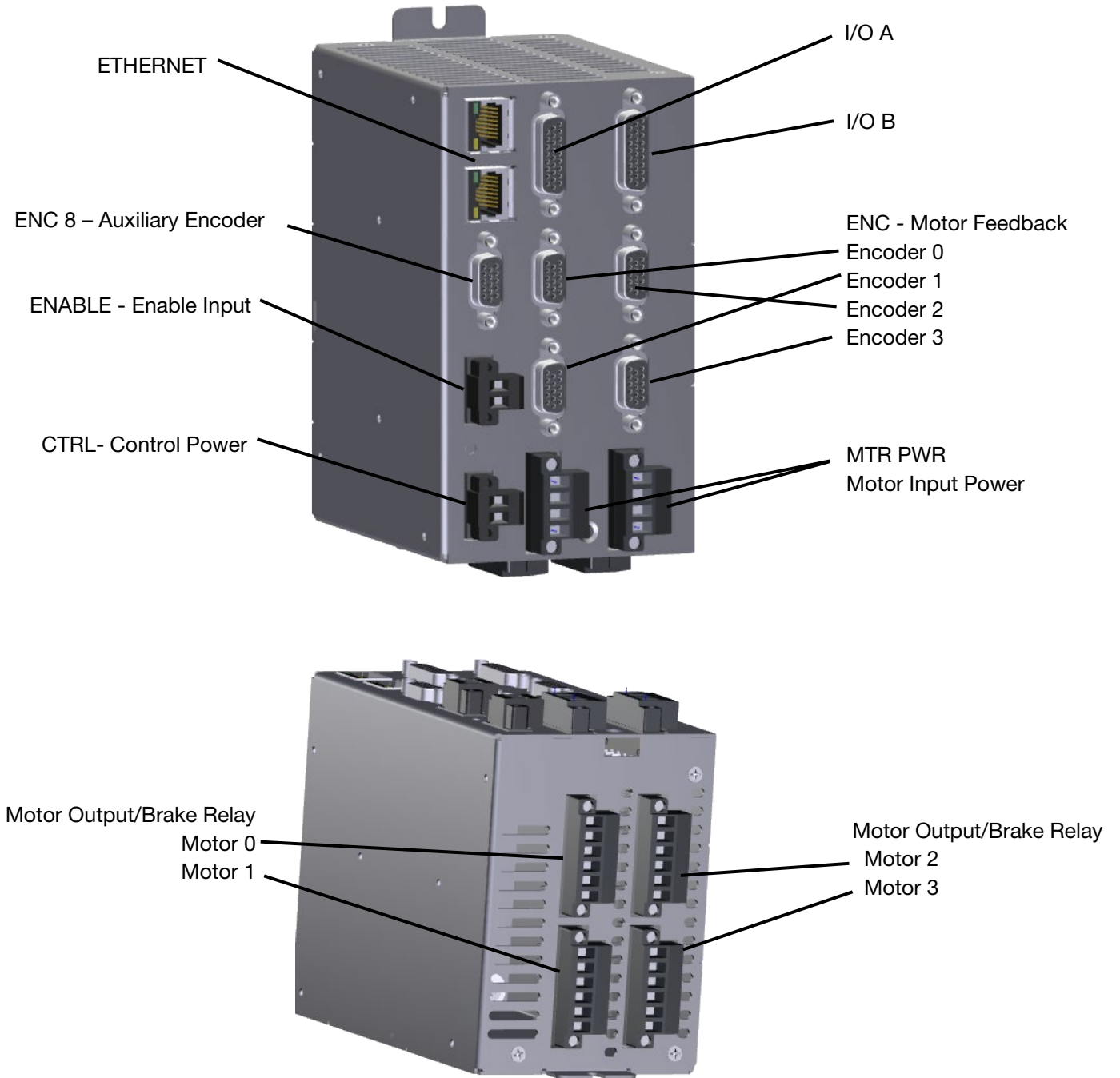

Figure 5. - ACR74V Connectors

## CTRL - Control Power Connector

The Control power connector provides power for:

- Logic for the controller and all drives
- Communications
- Encoders, halls and motor thermal sensors
- I/O logic and 24VDC output power
- Brake relays

### Control Power Connector

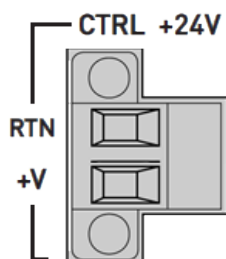

Description	Specification
Connector Type	Removable screw terminal
Terminals	2
Pitch	0.200 in (5.08 mm)
Wire range	12-24 AWG (0.34-2.5 mm <sup>2</sup> )
Wire strip length	0.3 in (7-8 mm)
Torque	5 in-lbs. nom. (0.5 N-m)
Manufacturer	OnShore or equivalent
OnShore Part Number	OSTTJ020152 (black) OSTTJ025152 (green)

### Control Power Rating

Description	ACR74V	ACR78V
Nominal Operating Voltage	24VDC	
Minimum Voltage	19VDC	
Maximum Voltage	30VDC	
Minimum Current (no encoders)	0.9A	1.6A
Maximum Current	9A	13A
Protection	Reverse Polarity, Overvoltage	

The power required for the control input depends on what external devices are supplied through the controller.

### Control Power Budget

Description	ACR74V	ACR78V
Minimum Required + Encoders	1.2A	2.0A
24VDC user output 1A per I/O Connector	2A	4A*
Brake Relay Output, 1.5A max per axis	6A	10A*

\*Combination of User Output and Brakes should not exceed 10A

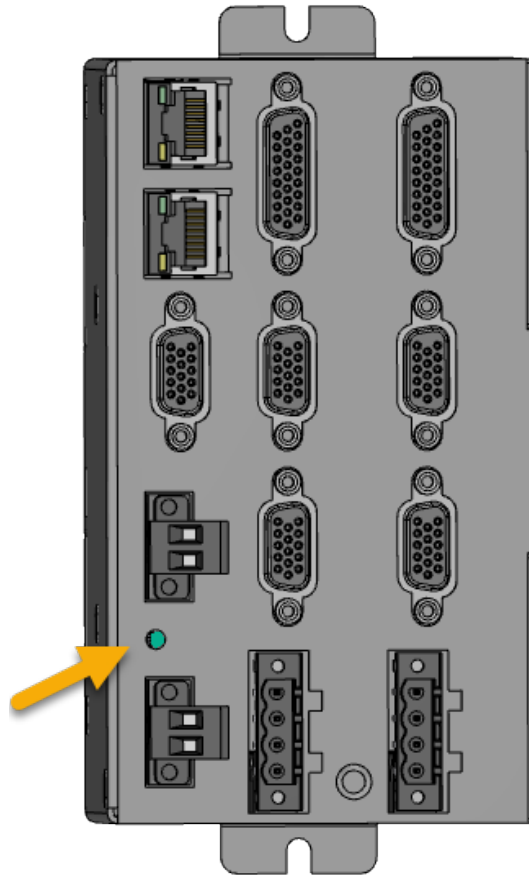
**Control Power LED**

The Control power LED indicates the operating status of the controller.

Color	Status
Off	Control Power is off.
Red	Booting (less 2 seconds)
Green	Ready

# ENABLE – Enable Input Connector

The Enable Input must be connected to 24VDC in order to enable/power the motors. If the input goes inactive, that inactive state is latched and the ACR7000 reacts by doing the following:

- Disabling the drives, no current to the motors
- Blocking motion commands

The status of the motion enable input is shown in BIT5646, where active is a cleared or 0 state, and inactive is a set or 1 state.

When the enable input goes inactive, BIT5645 is set and latched until voltage is present again on the enable input and either:

- The DRIVE ON command is issued for one of the Axes or,
- Clear Motion Enable Input Latch bit is asserted, SET BIT 5647

NOTE: The Motion Enable Input can be used as a part of a circuit to prevent motion and remove power from the motors. Note that if the input is deactivated while in motion, motors will stop immediately without a deceleration ramp.

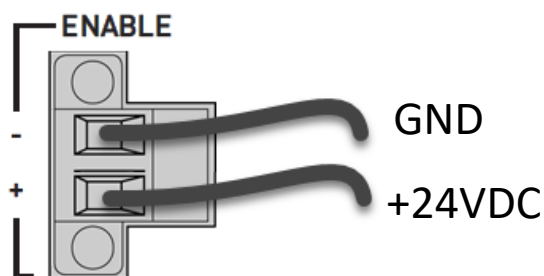

### Enable Connector

Description	Specification
Connector Type	Removable screw terminal
Terminals	2
Pitch	0.200 in (5.08 mm)
Wire range	12-24 AWG (0.34-2.5 mm <sup>2</sup> )
Wire strip length	0.3 in (7-8 mm)
Torque	5 in-lbs. nom. (0.5 N-m)
Manufacturer	OnShore or equivalent
OnShore Part Number	OSTTJ020152 (black) OSTTJ025152 (green)



## MTR PWR - Motor Input Power Connectors

The Motor Input power connectors provide input power for the servo motors. The number of motor connectors is dependent on the controller configuration. Each MTR PWR connector is dedicated to a pair of specific axes. These connectors are removable.

**Protections:** Overcurrent, Overvoltage and Short Circuit

### Motor Input Power

Description	Specification
Connector Type	Removable screw terminal
Terminals	4
Pitch	0.200 in (5.08 mm)
Wire range	12-26 AWG 14-27 SWG (0.12-3.30 mm <sup>2</sup> )
Wire strip length	0.31 in (7.87 mm)
Torque	7.0 in-lbs. nom. (0.79 N-m)

### Motor Power Rating

Description	Rating per Axis
Nominal Operating Voltage	24-48VDC
Minimum Input Voltage	19VDC
Maximum Input Voltage	56VDC
Maximum Current	22.6A <sub>pk</sub>
Overvoltage Protection	65VDC

**Power Supply Requirements:** Each motor may have different power requirements depending on speed and torque needed for the application.

$I(m)$  = motor current Arms (peak)

$I(s)$  = power supply current Adc

$I(s) = i(m) * 1.2$

Pin	Label	Description
1	RTN	VDC Return
2	+V(0)	+VDC for Motor 0
3	RTN	VDC Return
4	+V(1)	+VDC for Motor 1

Connectors have +V and RTN pins specific to a motor with the (x) designating the motor/drive number. For example, +V(1) supplies power for Motor/Drive 1. RTN pins are connected internally.

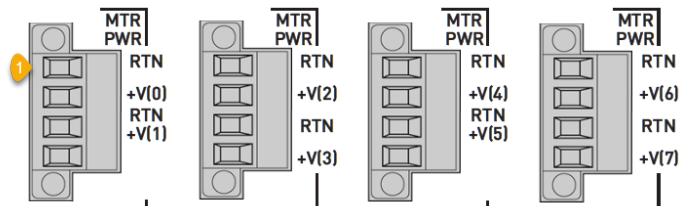

## ENC - Encoder Connectors

Inputs for the encoder feedback, motor thermal switch, and hall effects are located on the 15-pin Encoder connectors. Encoders 0 thru 7 all have the same pinout and specifications.

Encoder 8 utilizes the same 15-pin connector but only supports quadrature encoders (no halls, thermal switch or BiSS). Encoder 8 can be used as a source for GEAR and CAM following. Two digital inputs are included to support position capture functions. These inputs have the same specification as the general-purpose digital inputs. See page 35.

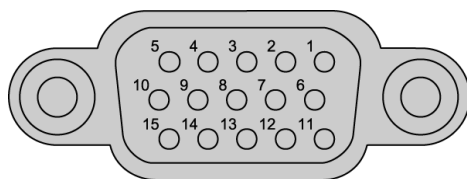

Figure 6. - Encoder Connector, Female

### Encoder Connector Specification

Description	Specification
Connector Type	15-Pin High Density D-Subminiature (female socket)
Manufacturer	KYCON or equivalent
KYCON Part Number	K66-E15S-NR

### Encoder Connector Specification—Mating Connector<sup>1</sup>

Description	Specification
Connector Type	15-Pin High Density D-Subminiature (male connector)
Manufacturer	TE Connectivity AMP or equivalent
Cable Kit includes:	TE Connectivity AMP Part Number 1658678-1: <ul style="list-style-type: none"> <li>• 1658678-1 connector</li> <li>• shield</li> <li>• enclosure</li> <li>• two jack screws</li> <li>• (does not include contacts or ferrules)</li> </ul>
Contacts	Crimp style: <ul style="list-style-type: none"> <li>• TE Connectivity AMP Part Number 1658670-2</li> </ul>

<sup>1</sup>Mating connectors are not provided with the drive. Parker cables are available with mating connectors attached.



**IMPORTANT:** Encoder inputs use a SN65C1168E differential line receiver. Parker Hannifin recommends 65C11 (or compatible) differential line driven encoders. Single ended encoders are supported but not recommended for noisy environments.

## Encoder Connector (0-7) Pinout

Pinout configuration for the Encoder connectors (0-7) are listed in the following table. A box surrounding pins indicates a requirement for twisted pair wiring.

### Encoder (0-7) Connector Pinout

Signal	Pin	Incremental Encoder	BiSS Serial Encoder
ENC Z+ / DATA+	1	Encoder Z Channel in	SLO
ENC Z- / Data-	2	Encoder Z Channel in	/SLO
DGND	3	Encoder power return	Encoder power return
+5 VDC	4	+5 VDC Encoder power	+5 VDC Encoder power
+5 VDC	5	+5 VDC Hall power	
DGND	6	Hall power return	
ENC A- / SIN-	7	Encoder A Channel in	
ENC A+ / SIN+	8	Encoder A Channel in	
Hall 1 / MA *	9	Hall 1 input	MA
Thermal+	10	Motor thermal switch/thermistor	
Thermal-	15	Motor thermal switch/thermistor	
ENC B- / COS-	11	Encoder B Channel in	
ENC B+ / COS+	12	Encoder B Channel in	
Hall 2 / MA- *	13	Hall 2 input	/MA
Hall 3	14	Hall 3 input	

\* When using the BiSS protocol, pins 9 and 13 require twisted pair wiring. Note: Twisted pairs are outlined by a box.

### NOTES:

The encoder input for the motors can be configured to use either quadrature encoders with halls or BiSS serial encoders.

- Two servo drives reside together on a circuit board and share an FPGA that handles encoder feedback. The controller requires that both drives on an axis pair (0 and 1, 2 and 3, 4 and 5, 6 and 7) must be the same encoder type, quad or BiSS.
- Default feedback type for all axes is quadrature encoder. **After changing the encoder type a controller REBOOT is required before operation.**
- Each encoder feedback port is fixed as the commutation source for an axis. That is, ENCI must be the commutation source for Motor 1 and DAC1 (command output).
- Axes can be assigned a different ENC as a position feedback source, if that encoder is on the same drive pair (0 and 1, 2 and 3, 4 and 5, 6 and 7). For example:

ATTACH AXIS0 ENCI DAC0 ENC0    assigns ENCI as the position feedback source for motor 0.



**IMPORTANT:** Encoder inputs use a SN65C1168E differential line receiver. Parker Hannifin recommends 65C11 (or compatible) differential line driven encoders. Single ended encoders are supported but not recommended for noisy environments.

## Internal Encoder (0-7) Connections

The following figure shows a schematic diagram of the internal connections for the Encoder connectors.

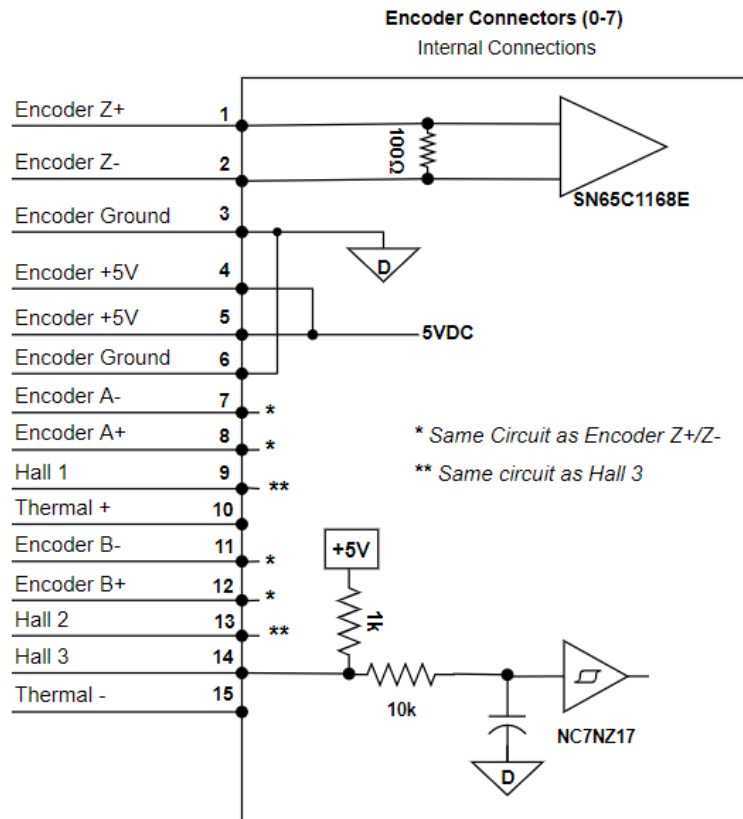

Figure 7. - Internal Circuit Diagram for the Motor Encoder Connectors

## Encoder Inputs (0-7)

Encoder input requirements are listed in the table below.

### Encoder Inputs

Description	Min	Typical	Max	Units
Common Mode Range	-7		+7	V
Current—Encoder			250	mA
Current—Hall			250	mA
Differential Threshold Voltage	-200		+200	mV
Differential Termination Impedance		120		ohms
Thermal Switch Current			2	mA
Thermal Switch Voltage Maximum (supplied)			15	V
Encoder Input Frequency (pre-quadrature)			2.5	MHz

**Note:** All parameters are at the connector pin.

## Motor Thermal Switch Input

The motor thermal input is designed to read a thermistor or thermal switch located in the motor. A constant 2mA current source is driven from the 24V supply through the switch and into ground. The resulting voltage across the switch is scaled by the controller to determine temperature, or switch state,

- Omega 44004 Thermistor
- Philips KTY84-130 Thermistor
- Thermal Switch, typically normally closed. Can be configured in software to accept N.O.

## Encoder Connector (ENC8) Pinout

Pinout configuration for the Encoder connectors 8 is listed in the following table. A box surrounding pins indicates a requirement for twisted pair wiring.

Two digital inputs are present on ENC8 connector

- High speed for encoder position capture functions (INTCAP)
- Schmitt Trigger with Zener Diode and RC filter, non-isolated.
- Short circuited protected
- 24VDC pull-up, 4.75k resistor
- Inputs are active when switched to DGND
- Compatible with NPN sensors

### Encoder 8 Connector Pinout

Signal	Pin	Incremental Encoder
ENC Z+	1	Encoder Z Channel in
ENC Z-	2	Encoder Z Channel in
DGND	3	Encoder power return
+5 VDC	4	+5 VDC Encoder power
+5 VDC	5	+5 VDC Encoder power
DGND	6	Encoder power return
ENC A-	7	Encoder A Channel in
ENC A+	8	Encoder A Channel in
N/A	9	No Connect
DGND	10	Digital Ground
ENC B-	11	Encoder B Channel in
ENC B+	12	Encoder B Channel in
Hall 2	13	Hall 2 input
Hall 3	14	Hall 3 input
DGND	15	Digital Ground

## Internal Encoder 8 Connections

The following figure shows a schematic diagram of the internal connections for the Encoder 8 connector.

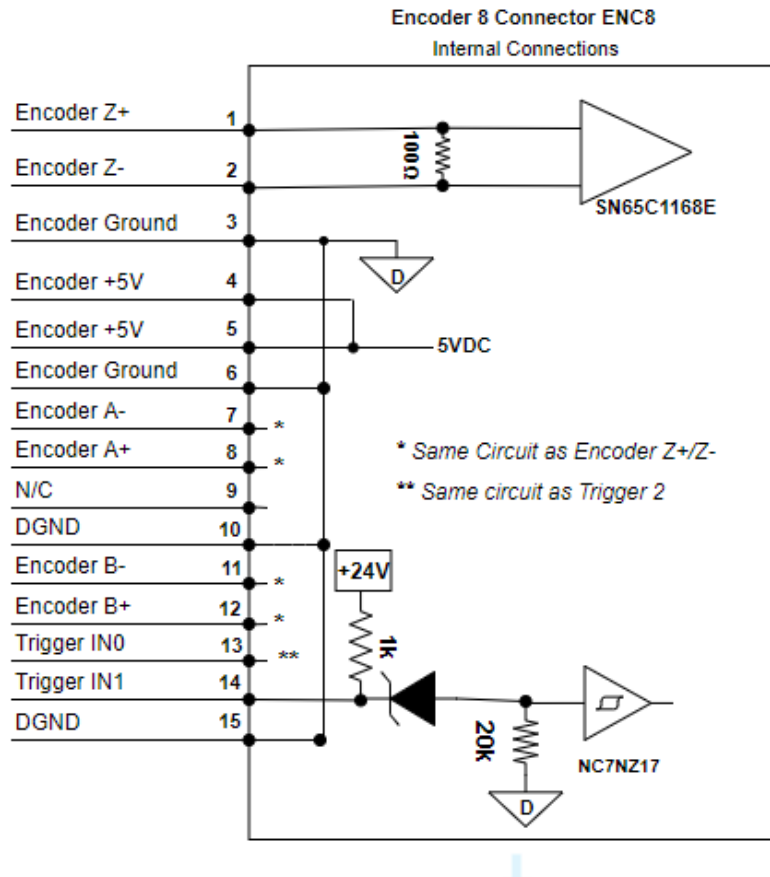

## I/O Connectors

The ACR7000 Servo features inputs and outputs which are accessible using the 26-Pin D-Sub connectors. The 8 axis ACR78V includes connectors A, B, C, D while the 4 axis ACR74V has only A and B.

I/O per connector

- Six general purpose digital inputs
- Four high speed trigger inputs
- Six digital outputs
- One analog input, 12-bit resolution
- 24VDC source for outputs, 1Amp

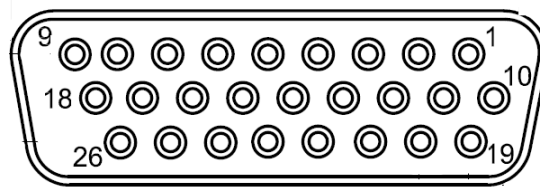
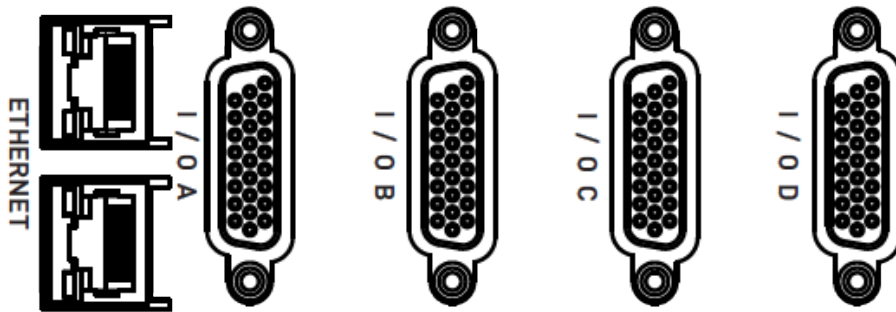

Figure 8. - I/O Connectors



### I/O Cable

For preparing your own cable, use differential pair wiring with a minimum of three turns-per-inch (3 TPI).

#### I/O Connector Specification

Description	Specification
Connector Type	26-Pin D-Subminiature (female socket)
Manufacturer	KYCON or equivalent
KYCON Part Number	K66X-A26S-NR

#### I/O Connector Specification—Mating Connector<sup>1</sup>

Description	Specification
Connector Type	26-pin, high density D-sub, 3-row (male connector)
Manufacturer	TE Connectivity AMP Connectors or equivalent
Cable Kit	AMP Part Number 1658679-1 includes: <ul style="list-style-type: none"><li>• 1658679-1 connector</li><li>• shield</li><li>• enclosure</li><li>• two jack screws</li><li>• (does not include contacts or ferrules)</li></ul>
Contacts	Crimp style: TE Connectivity AMP Part Number 1658670-2

<sup>1</sup> Mating connectors are not provided with the drive.



## I/O Connector Pinout

Pinout configuration for the I/O connectors are listed in the following table.

### I/O Connector Pinout

	I/O Connector A		I/O Connector B		I/O Connector C		I/O Connector D	
Pin	Signal	BIT#	Signal	BIT#	Signal	BIT#	Signal	BIT#
1	Input 0	0	Input 6	6	Input	12	Input	18
2	Input 1	1	Input 7	7	Input	13	Input	19
3	Input 2	2	Input 8	8	Input	14	Input	20
4	Input 3	3	Input 9	9	Input	15	Input	21
5	Input 4	4	Input 10	10	Input	16	Input	22
6	Input 5	5	Input 11	11	Input	17	Input	23
7	Input (TRG)	24	Input (TRG)	28	Input (TRG)	72	Input (TRG)	76
8	Input (TRG)	25	Input (TRG)	29	Input (TRG)	73	Input (TRG)	77
9	Input (TRG)	26	Input (TRG)	30	Input (TRG)	74	Input (TRG)	78
10	Input (TRG)	27	Input (TRG)	31	Input (TRG)	75	Input (TRG)	79
11	GND		GND		GND		GND	
12	Output 32	32	Output	36	Output	3584	Output	3588
13	Output 33	33	Output	37	Output	3585	Output	3589
14	Output 34	34	Output	38	Output	3586	Output	3590
15	Output 35	35	Output	39	Output	3587	Output	3591
16	GND		GND		GND		GND	
17	NC		NC		NC		NC	
18	GND		GND		GND		GND	
19	24VDC output		24VDC output		24VDC output		24VDC output	
20	Analog in +		Analog in +		Analog in +		Analog in +	
21	Analog in -		Analog in -		Analog in -		Analog in -	
22	Output (5V)	3600	Output (5V)	3602	Output (5V)	3604	Output (5V)	3606
23	Output (5V)	3601	Output (5V)	3603	Output (5V)	3605	Output (5V)	3607
24	GND		GND		GND		GND	
25	GND		GND		GND		GND	
26	GND		GND		GND		GND	

## Digital Inputs

Ten digital inputs present on each I/O connector

- Six inputs are general purpose – Pins 1-6
- Four inputs are high speed for encoder position capture functions (INTCAP) – Pins 7-10
- Schmitt Trigger with Zener Diode and RC filter, non-isolated.
- Short circuited protected
- 24VDC pull-up, 4.75k resistor
- Inputs are active when switched to DGND
- Compatible with NPN sensors

### Digital Input Specification

Description	General Purpose	High Speed
Turn-on time*	20 $\mu$ s	300 ns
Turn-off time*	20 $\mu$ s	300 ns
Threshold voltage rising	16.1V	16.1V
Threshold voltage falling	11.6V	11.6V

\*On/Off time indicates propagation delay only. When used as general input, state change is detected at the PERIOD.

### Input Circuit, PINS 1-10

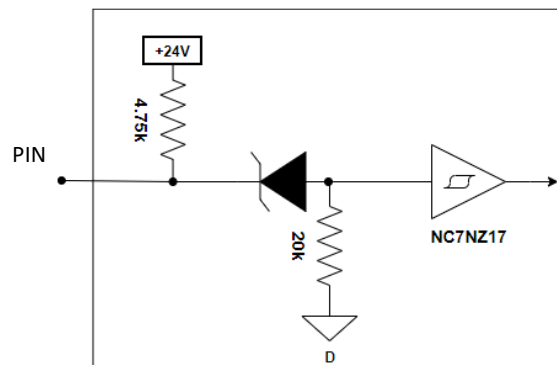

## Outputs—General Purpose

Four general purpose digital outputs are present on each I/O connector - PINS 12-15

- Current-sinking MOSFET, non-isolated
- Overcurrent, Overtemperature, Overvoltage protection.
- 24VDC pull-up, 4.75k resistor
- Outputs sink current to GND
- PIN 19 provide up to 1A for driving outputs – optional

Output Circuit, PIN 12-15

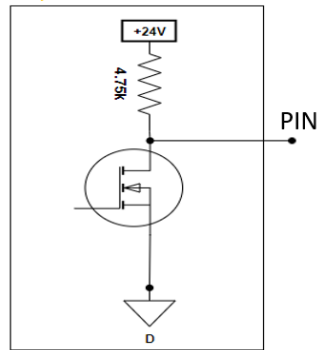

### Outputs —General Purpose

Description	Value
Maximum Sink Current	0.75A
Maximum Voltage	42V
Turn-on time	200 $\mu$ s
Turn-off time	40 $\mu$ s
Short circuit trip current	1.5A

## Outputs—High Speed

Two High Speed digital outputs are present on each I/O connector - PINS 22-23

- 5V push-pull outputs can source and sink at least 20 mA
- SN65C1168 Differential Driver
- Overcurrent protection
- Compatible with NPN sensors
- Ideal for Output On Position functions (OOP)

### Outputs —High Speed

Description	Value
Valid High	3.4V @ 20mA
Valid Low	0.2V @ 20mA
Turn-on time	200ns
Turn-off time	200ns

### *Analog Inputs*

One analog input per I/O connectors,

- 12-bit resolution
- 0-10VDC range
- Differential
- Requires ADC ON and ADC MAX commands in controller activate

Pin	Description
20	Analog in +
21	Analog in -

## Motor Output Power Connectors

Each axis has a removable screw terminal connector which provides output power to the motor.

The Motor connector provides terminals U, V, W and  $\perp$  for connecting output power to the motors. It also serves to connect an external motor brake to the internal solid-state relays on the two BK terminals.

### Motor Screw Terminal Connector Specifications

Description	Specification
Connector Type	Removable screw terminal
Terminals	6
Pitch	0.200 in (5.08 mm)
Wire range	12-26 AWG 14-27 SWG (0.12-3.30 mm <sup>2</sup> )
Wire strip length	0.310 in (8 mm)
Torque	7.0 in-lbs. nom. (0.79 N-m)

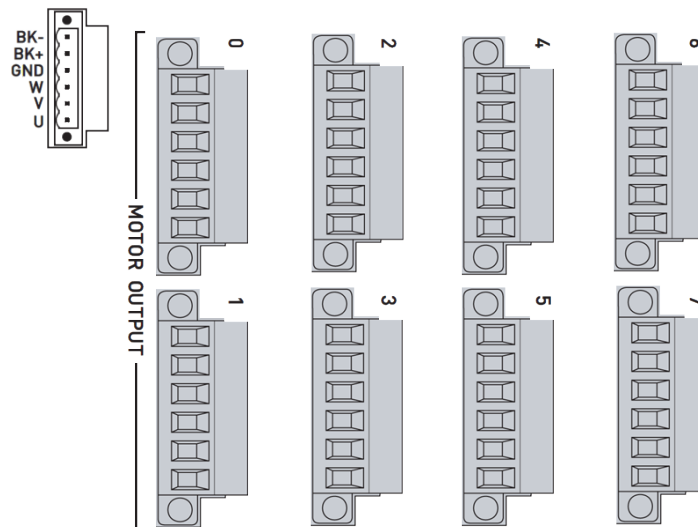

Figure 1. - Output Power Connectors – ACR78V

## Motor Output Power

### Output Power Ratings

Model		
	Continuous Current	Peak Current
ACR7xV-A5V4C1	5A <sub>rms</sub>	16A <sub>rms</sub>

## Motor Output Power Connections

The following figure shows examples how to connect the motor cable to the Output Power connector.

Parker motor cables are marked by number 1,2,3 or letters UVW:

- Black leads marked with white numbers (1, 2, or 3) to indicate the phase. Connect Motor Phase 1 to U, 2 to V, and 3 to W, and Motor Safety Earth to the Protective Earth ground connector.
- Color coded and marked with UVW designations. Red (U), White (V), Black (W)

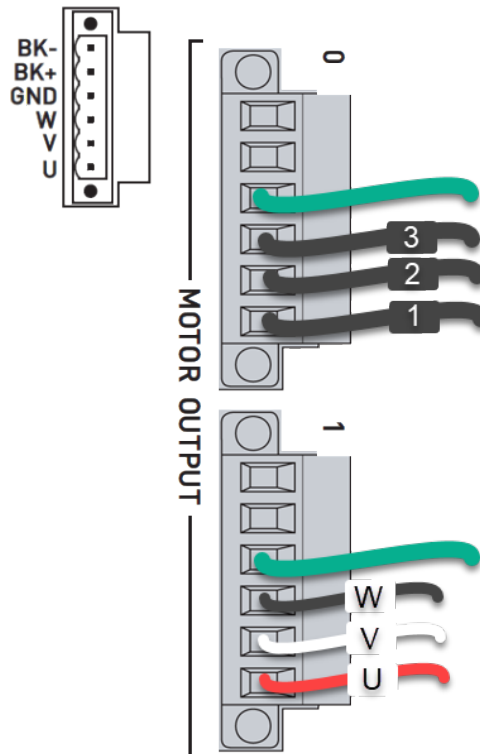

Figure 2. - Output Power Connection



**Warning:** You must connect the Motor Safety Earth conductor terminal, marked **GND** to the motor cable's motor-safety-earth wire green/yellow).

The following table contains wiring information for making connections with various Parker Hannifin motors series.

### Wiring to Parker Motors

Phase	BE/SM with PS cables	P Series (APCS-P)	Legacy Parker Hannifin
U	1	Red (U)	Red/Yellow
V	2	White (V)	White/Yellow
W	3	Black (W)	Black/Yellow
⊥	Green/Yellow	Green	Green/Yellow

## Brake Relay/Brake Power (Optional)

The Brake Relay connection (on the Output Power connector) provides a safety feature for your motion control system, particularly for vertical applications. The drive/controller acts as a control switch for the motor brake (if a brake is present). The connection supplies 24VDC up to 1.5 A for power the brake. The control will automatically close the relay to supply current to the brake when the drive is enabled, allowing motion. When the axis is disabled or faults the controller will automatically

### Brake Relay (on Output Power Connector)

Description	Connections
Connector Type	Removable screw terminal
Terminals	6
Pitch	0.200 in (5.08 mm)
Wire range	12-26 AWG 14-27 SWG (0.12-3.30 mm <sup>2</sup> )
Wire strip length	0.310 in (8 mm)
Torque	7.0 in-lbs. nom. (0.79 N-m)

### Brake Relay Operation

#### Brake Relay Operation

Axis Condition	Relay State
Enabled	Closed (conducting)
Faulted/Disable	Open

### Brake Relay Specifications

Description	Specification
Relay Type	Solid State Relay Normally open
Maximum Supply Voltage	1.5 Amp at 24 VDC



**Warning:** Do not exceed the ratings of the brake relay. If required, control a suitable external relay with this relay to meet your power requirements.

## Brake Relay Connection

### Regeneration Protection

The ACR7000V Servo drives include internal regeneration dump resistors.

#### Regeneration Specifications

Specification	Value per axis
Voltage threshold, on	60 V
Voltage threshold, off	57 V
Overvoltage threshold	65 V
Peak Dissipation	384W 5.9A 300ms
Capacity	168 uF
Resistance	11 $\Omega$





# CHAPTER 4

## Communications



## Overview

The ACR7000 Servo communicates in a standard Ethernet network, thereby providing a direct link for sending commands through the Parker Motion Manager software installed on a PC. This chapter describes how to establish the standard Ethernet connection.

The controllers have a dual-stack, standard RJ-45 connector, which provides two communications ports. The two ports act as a hub, with a single IP address.

## Ethernet Specifications

### *Ethernet Cable Specification*

Use a braid over foil twisted pair cable (straight or crossover) for connection to a PC. An example of this type of cable is L-COM TRD855SIG-XX. The maximum recommended cable length is 30m.

### *Ethernet Connector*

A standard RJ-45 socket connector, located on the front panel of the drive/controller, provides two communication ports that accommodate ETHERNET connections. The two sockets of the connector are identical, and either may be used for direct connection to a PC network card.

To provide top noise performance, the connector contains isolation transformers and common mode chokes for both the transmit and receive signal pairs.

#### *Connector Specifications*

Description	Specification
Manufacturer	Abracom
Connector Type	8-Pin, RJ-45 (female socket)
Abracom Part Number	ARJ11D-MBSK-A-B-IMU2

## COMMUNICATIONS

### Ethernet Connector Pinout

The following table contains the Ethernet connector pinout.

#### RJ-45 Connector Pinout

Signal	Pin	Wire Color	Description
RX+	1	White with orange	Differential Receive positive side
RX-	2	Orange	Differential Receive negative side
TX+	3	White with green	Differential Transmit positive side
	4	Blue	Not used
	5	White with blue	Not used
TX-	6	Green	Differential Transmit negative side
	7	White with brown	Not used
	8	Brown	Not used

Note: Pin assignment follows EIA/TIA T568B guidelines.

### RJ-45 LED Ethernet Status Indicators

LEDs located on the RJ-45 socket connector indicate Ethernet status. The next table describes the LED states and their meanings.

#### RJ-45 Ethernet Status LED Indications

Signal	Steady	Flash	Description
Ethernet Link/Activity	Off	—	No Ethernet link detected
	Yellow	—	Ethernet link established, no activity
	—	Yellow	Ethernet link established and active
Ethernet Speed	Off	—	Ethernet 10Mbps
	Green	—	Ethernet 100Mbps

## Connecting to a PC

Connect one end of an Ethernet cable to the PC. Connect the other end to one of the ACR7000 Servos two RJ-45 socket connectors. The two RJ-45 sockets can be used interchangeably.

### Turn on Control Power to the ACR7000.

The ACR7000 has a programmed IP address. The factory default address is shown below. This address can be changed later in software after initial communication is established. The IP address for the PC will need to be assigned to a compatible address to communication with the ACR. These steps are detailed below.

#### Default IP Address— ACR7000 Servo

The factory assigns the following to each ACR7000 Servo

<b>IP Address</b>	<b>Subnet Mask (fixed)</b>
192.168.100.01	255.255.255.0

## Setting the IP Address and Subnet Mask—PC

Set the IP address and Subnet mask for your PC. (These instructions are for Windows 10 users. If you have another Windows version, the steps may vary. Please consult your Network Administrator.)

- 1 Open the Window Search tool
- 2 Enter **Change Ethernet Setting**
- 3 Select **Change Ethernet settings**

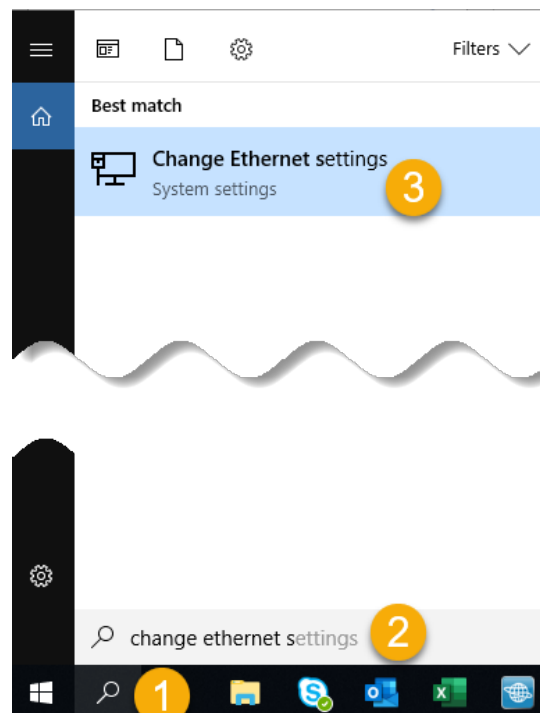

- 4 Select **Change adapter options**.

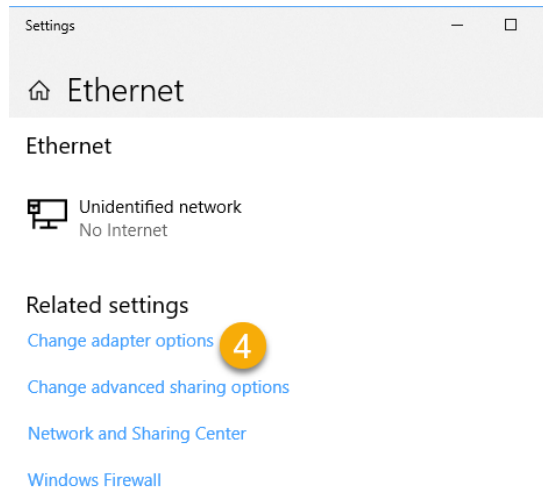

- 5 Select **Ethernet**. More than one Ethernet connections may be displayed. When a cable is inserted to ACR and PC and ACR is powered on the Ethernet connections will show as “Unidentified network”

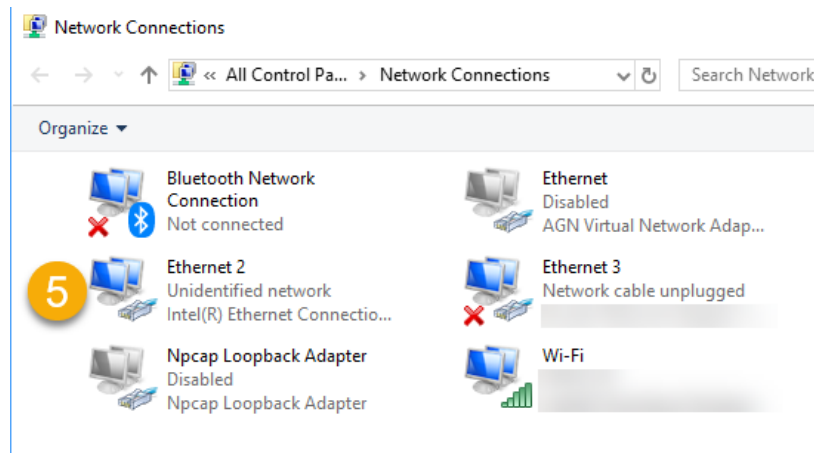

- 6 Click **Properties**. Administrator rights may be required.

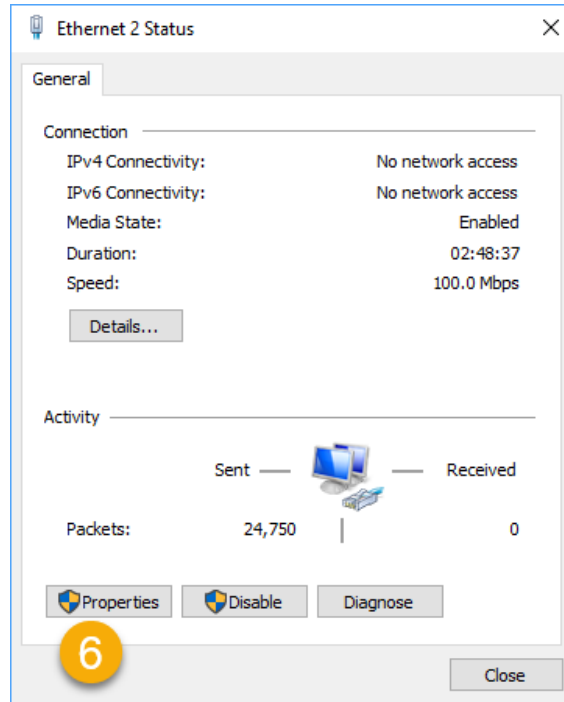

- 7 Select **Internet Protocol Version 4 (TCP/IPv4)**
- 8 Click **Properties**.

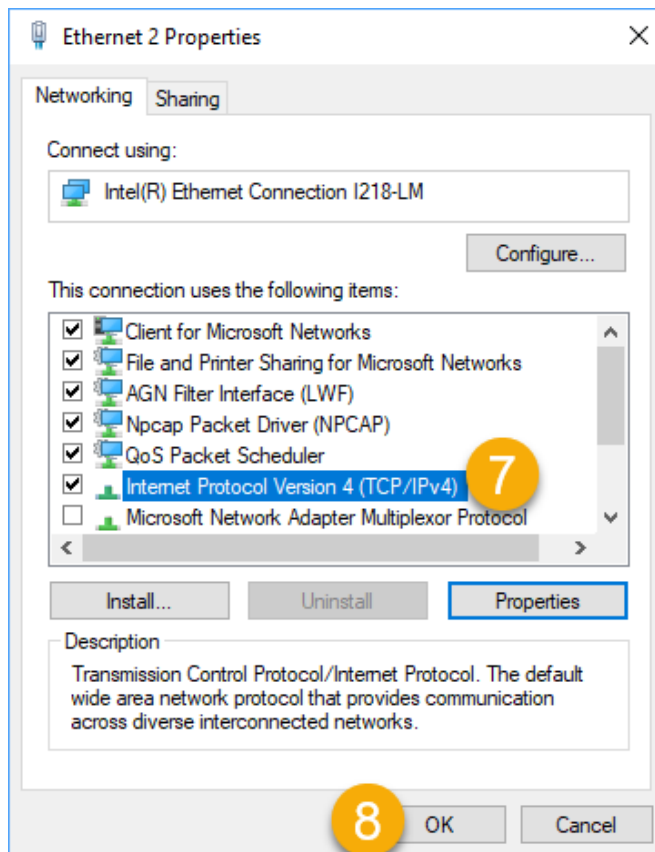

- 9 Click the radio button next to **Use the following IP address**
- 10 Enter an IP address with the same first three octets as the default ACR7000 IP address (192.168.100). The last octet of the ACR7000 is by default "1". Select a different number for the PC in the valid range is 1 to 254. Using 000 or 255 is not valid. In the example the IP address is set to 192.168.100.222. Set the Subnet mask value to 255.255.255.0. Your window should look like the following:

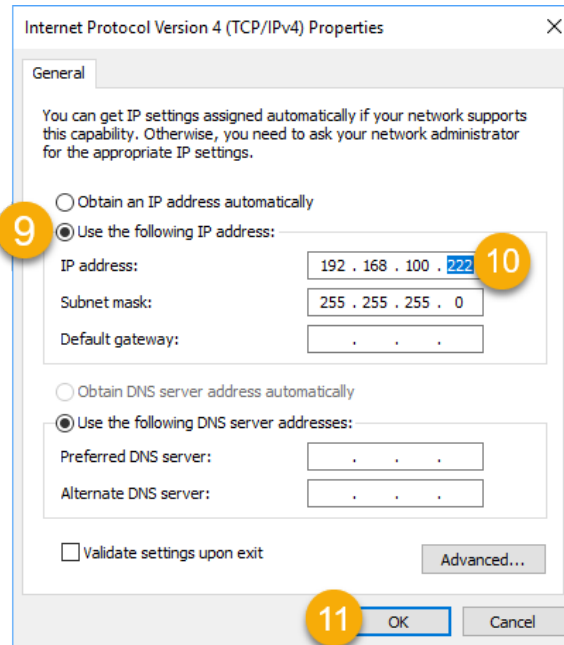

Figure 3. - Internet Protocol Properties Screen Completed

- 11 Click **OK**. It is now safe to close these windows.



**IMPORTANT:** It is good practice to isolate the **ACR7000** and related devices on their own subnet so that their performance is not affected by high volume network traffic.

## Verifying the IP Address

The following verifies the Ethernet is set up correctly.

- 1 In Parker Motion Manager, the IP Address box is the value for the controller.
- 2 In the dialog box, click **Connect**.
- 3 In the Terminal Emulator, type VER. If the Ethernet is set up correctly, the terminal emulator reports the firmware version information for the ACR7000 Servo.





**CHAPTER 5**  
**Basic Operation**



# Basic Operation

The ACR7000 Servo controllers are programmable products that support a wide array of 3-phase rotary and linear servo motors. Other motion control functions such as limit and home switches, programming units and axis scaling are also configurable. The controller is delivered as a blank slate and the user will need to tailor the settings to meet the needs of each application.

## Parker Motion Manager

Parker provides a software development tool to facilitate the setup and programming of the ACR controllers: Parker Motion Manager (PMM). Parker Motion Manager includes a configuration wizard, program editors, a terminal emulator, status panels and software oscilloscopes. PMM also includes a Help system with extensive documentation on using all the ACR family controllers. A section is dedicated to the ACR7000 Servo.

### Configuration Wizard

The Configuration Wizard guides the user through the necessary steps for controller setup. Below is a summary of each step.

#### Axes

Create an *Alias* or nickname for each axis, remove unused axes from the configuration and assign the axes to a *Master* or axis group. Axes assigned to the same group can participate in interpolated motion.

Axes summary

Click on an "Alias", "Command Output", or "Master" cell to edit its value.

Axis	Alias	Command Output	Master
0	X	Internal Servo Drive 0	Master 0
1	Y	Internal Servo Drive 1	Master 0
2	Z	Internal Servo Drive 2	Master 0
3	A	Internal Servo Drive 3	Master 0

*Note: A dropdown menu is open for the 'Command Output' of Axis 3, showing options: Internal Servo Drive 3 and Not Used.*

#### Master

Select the desired programming units for the axes in the Master group.

Master Name (Alias)

---

Units

Inches
  Millimeters
  Degrees
  Revolutions
  Counts
  Other

---

Master Motion Defaults

Acceleration Ramp  Inches/sec/sec  
 Velocity  Inches/sec  
 Deceleration Ramp  Inches/sec/sec  
 Stop Ramp  Inches/sec/sec

## BASIC OPERATION

### Drive/Motor

Each axis to be used must have valid motor parameters for proper operation.

- Select the motor connected to the axis, matching the part number from the motor nameplate
- Select Cooling Method for the motor. (*Heatsink* in most cases)
- By default, a positive motion command will turn a motor in the clockwise direction. Select invert to change motor direction as needed.
- To view the detailed motor parameters, check Show Advanced Motor Parameters

Motor/Drive Parameters are downloaded with the full controller configuration and saved as part of the project.

Select Motor Part Number (from Motor Nameplate)

Series	Frame	Stack	Winding	Feedback
BE	16	1	C	J

Select Cooling Method

Heat Sink  Invert Motor Direction

Note: Changing the motor part number or cooling method will reset the fields in 'Advanced Motor Parameters' to their default values.

Show Advanced Motor Parameters

Reset to Default

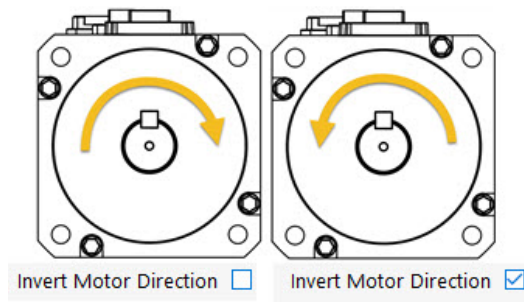

### Advanced Motor Parameters

View the detailed parameters that configure the drive using the motor's electrical, mechanical and feedback characteristics.

ACR74V:Master 0 (Master 0):00 Axis 0:Advanced Motor Parameters

Edit Your Motor Parameters (Advanced):

Motor Part Number: BE161CJ

Parameter	Parameter Name	Units	Value	Motor Default	MinValue	MaxValue	Description
28674	Feedback Resolution	counts/rev	8000	8000	32	1073741823	Rotary motor: Counts per full re
28704	Continuous Current	A rms	2.03	2.03	0	200	Continuous operating current in
28705	Continuous Current Derating	%	7.11	7.11	0	100	Current derating percentage at
28706	Peak Current	A rms	6.08	6.08	0	400	Maximum allowable current for
28707	Motor Inductance	mH	13.74	13.74	0	200	Maximum value of motor induct
28708	Motor Inductance Factor	n/a	0.76	0.76	0	1	Minimum motor inductance divi
28709	Motor Maximum Temperature	deg. C	125	125	0	200	Maximum allowable motor wind

**Feedback**

Each encoder feedback port is fixed as the commutation source for an axis. That is, ENCI must be the commutation source for Motor 1 and DAC1 (command output).

Axes can be assigned a different ENC as a position feedback source, if that encoder is on the same drive pair (0 and 1, 2 and 3, 4 and 5, 6 and 7). For example, a linear encoder used on a ball screw stage. The rotary motor is attached to Axis0 with the rotary feedback connected to ENC0. The linear encoder would then be connected to Encoder 1. Drive 1 would need to be set to “Not Used” in the initial Axes dialog.

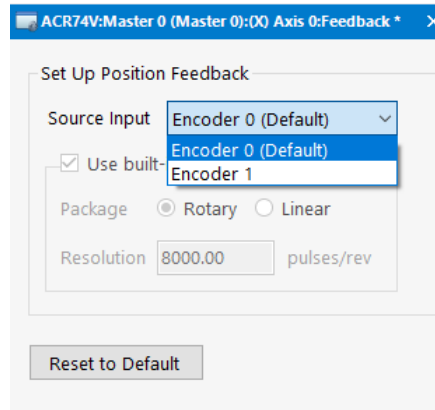

**Scaling**

Enter information about the system mechanics to create the axis scaling.

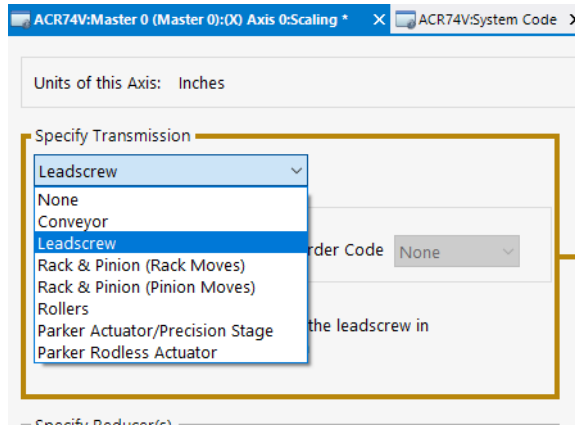

## BASIC OPERATION

### Fault

Position error settings must be non-zero values. Note that units are user programming units. Optionally select inputs used for hardware limit and home operation and soft limit detection.

The screenshot shows the 'Fault Detection' configuration window for 'ACR74V:Master 0 (Master 0):00 Axis 0:Fault'. It is divided into several sections:

- Hardware Limit Detection:** Includes checkboxes for 'Enable Positive Hardware Limit Detection' and 'Enable Negative Hardware Limit Detection'. A 'Hardware Limit Deceleration' field is set to 500.00 Inches/S<sup>2</sup>.
- Assign Digital Inputs For Specific Functions:** A table with columns 'Name', 'Description', and 'Value'.

Name	Description	Value
Positive Limit	Specific Input assigned as the positive limit	No Onboard Input
Positive Limit Input Type	Normally Closed = 'SET', Normally Open = 'CLR'	<input checked="" type="checkbox"/> Normally Closed
Negative Limit	Specific Input assigned as the negative limit	No Onboard Input
Negative Limit Input Type	Normally Closed = 'SET', Normally Open = 'CLR'	<input checked="" type="checkbox"/> Normally Closed
Home Limit	Specific Input assigned as the home limit	No Onboard Input
Home Limit Input Type	Normally Closed = 'SET', Normally Open = 'CLR'	<input type="checkbox"/> Normally Open
- Software Limit Detection:** Includes checkboxes for 'Enable Positive Limit' and 'Enable Negative Limit', both set to 0.00 Inches. A 'Software Limit Deceleration' field is set to 500.00 Inches/S<sup>2</sup>.
- Maximum Position Error Detection:** A highlighted section with fields for 'Positive Position Error' (1.00 Inches) and 'Negative Position Error' (-1.00 Inches).

### Memory

Allocate memory for user programs. Default values are a useful starting point for most applications. These values can be refined later as needed.

### Finish

Download the configuration to the controller. Note that when *Download Configuration* is selected all Defines and User programs will be cleared first.

**DO NOT CYLCE POWER DURING DOWNLOAD AND SAVE.**

The screenshot shows the 'Configuration Wizard - Errors & Warnings' dialog box. A 'Download Project' sub-dialog is open, showing the following options:

- Controller: ACR74V
- Download Configuration
- Download Defines
- Download Program(s) All Programs
- Save configuration, programs to flash memory

Buttons for 'OK' and 'Cancel' are visible. Below the sub-dialog, the main dialog has a checkbox for 'Download configuration to controller on Finish' which is checked, and buttons for '< Previous' and 'Finish'.

**Memory**

The ACR7000 Controller utilizes FLASH memory for saving programs and some system and user variables. Storing programs and variable values in FLASH memory requires the use of the FLASH IMAGE command while programs are stopped. Non-Volatile User FRAM store values automatically.

ESAVE command is issued with any configuration or program download. FLASH IMAGE is issued when checked

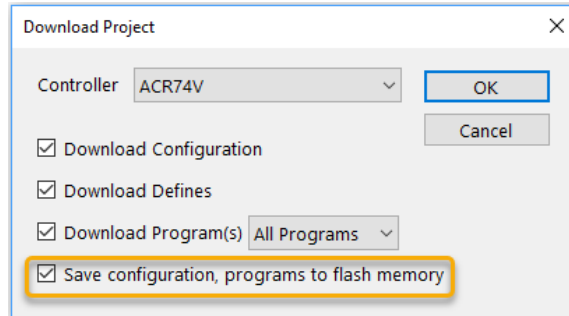

FLASH IMAGE operation can take approximately thirty seconds.

Memory Commands	
ERASE	Erases motor configuration parameters and drive setup parameters and sets to default. Resets system set-up and axis configuration parameters.
FLASH ERASE	Clears stored programs and user variables
FLASH RES	Clears all programs, set-up parameter, motor configuration and user memory. Used to return controller to factory settings.
ESAVE	Saves system configuration and axis set-up parameters. ESAVE is sent automatically with ACR-View downloads
FLASH SAVE	Saves user programs to FLASH memory
FLASH IMAGE	Saves user programs, local and global variables to FLASH MEMORY. User is prompted by PMM to FLASH IMAGE on project and program downloads.



**Warning:** To avoid possible memory corruption, do NOT cycle power during FLASH memory operations

## BASIC OPERATION

---

### Changing Motor/Drive Parameters

In most cases any changes to the motor/drive specific parameters should be performed using the configuration wizard. These parameters can also be changed using the terminal or user programs. Changes are not applied until the **DRIVE RES** command is issued for the Axis. For example, AXIS1 DRIVE RES.

Use the **ESAVE** command to retain motor/drive parameters.

### Motor Feedback

The encoder input for the motors (excluding ENC8) can be configured to use either quadrature encoders with halls or BiSS serial encoders. Two servo drives reside together on a circuit board and share an FPGA that handles encoder feedback. The design requires that both drives on an axis pair (0 and 1, 2 and 3, 4 and 5, 6 and 7) must be the same encoder type, quad or BiSS.

Default feedback type for all axes is quadrature encoder. After changing the encoder type a controller REBOOT is required before operation.

Each encoder feedback port is fixed as the commutation source for an axis. That is, ENCI must be the commutation source for Motor 1 and DAC1 (command output).

Axes can be assigned a different ENC as a position feedback source, if that encoder is on the same drive pair (0 and 1, 2 and 3, 4 and 5, 6 and 7). For example

ATTACH AXIS0 ENCI DAC0 ENC0 assigns ENCI as the position feedback source for motor 0.

### Commutation and Hall Checking

When a motor is configured to use a quadrature encoder with halls, the initial motor commutation uses the halls to determine the correct phasing. This occurs the first time the drive is enabled after power cycle or REBOOT. The DRIVE RES command will also force initial motor commutation. After initial commutation alignment with halls, the drive switches to using the encoder for sinusoidal commutation.

The encoders do not have loss detection circuit, instead the hall signals are checked continuously during sinusoidal commutation. A bad hall state (0 or 7) will report a fault and disable the drive. If spurious hall faults occur during operation, this hall check can be disabled with *Skip Continuous Hall Check* (parameter [P28790](#) for Axis 0).

BiSS encoders use the single turn absolute position for initial commutation alignment. Loss of the BiSS signals will result in a drive fault.





# **Appendix A**

## **Accessories**



## VM26 Breakout Module

The VM26 expansion module provides screw-terminal connections for the I/O connections. The VM26 comes with a 2-foot cable (609.6 mm) that provides easy connection between the VM26 module and the axis 26-pin connector. The VM26 expansion module is ordered separately (part number VM26-PM).

### Notes

- The VM26 module ships with DIN-rail mounting clips installed.
- The overall cabinet depth with cable-bend radius is 5 inches (127 mm).

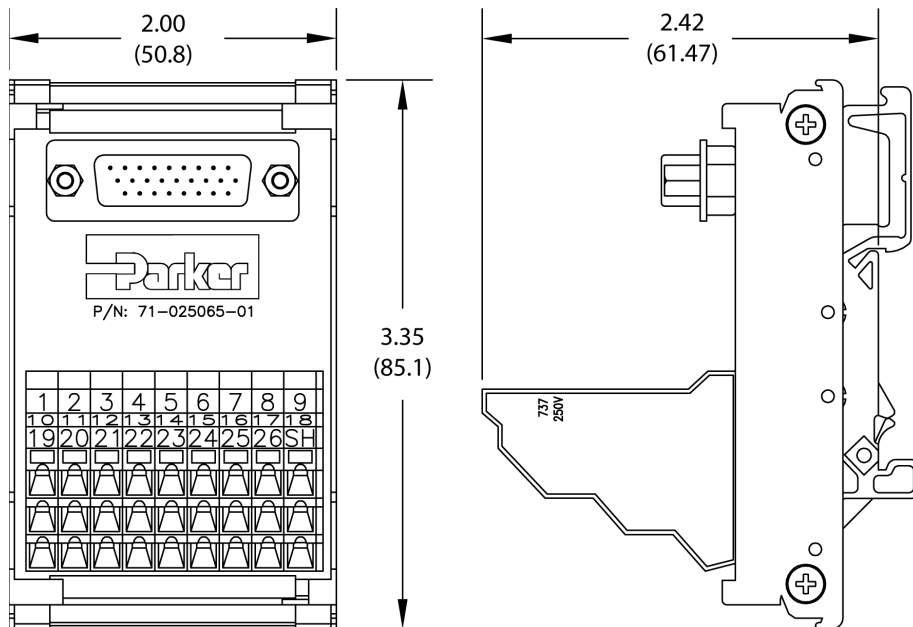

# Cables

The ACR7000 Servo controllers are programmable products that support a wide array of 3-phase rotary and linear servo motors. The follow cables are used with Parker motors.

Motor Family	Feedback Type	Cables		Feedback Cables	
		Motor Power Cables		Standard	High Flex
BE	Incremental w/halls	P-IAI-XX	PH-IAI-XX	F-IAI-XX	FH-IAI-XX
SM	Incremental w/halls	P-IAI-XX	PH-IAI-XX	F-IAI-XX	FH-IAI-XX
PM	BiSS-C Multiturn Absolute	APCS-PNyyLS	APCS-PFyyLS	71-032751-yy	71-032752-yy
mSR	Incremental w/halls	006-2690-01			
	BiSS-C Absolute	consult factory			
mPR	Incremental w/halls	006-2690-01			
404LXRxxx	Incremental w/halls	N/A	006-1741-mm	N/A	006-1889-mm
406LXRxxx	Incremental w/halls	N/A	006-1740-mm	N/A	006-1889-mm

XX - cable length in ft

yy - cable length in meters

mm - denotes cable length in meters